

# Development of Atmospheric Pressure Type Turbomolecular Pump

by Hiroyuki KAWASAKI\*, & Hiroaki OGAMINO\*\*

A novel atmospheric pressure type turbomolecular pump has been developed for the microchip/IC manufacturing industry, as well as for SEM applications. This pump makes it unnecessary to use backup by auxiliary pumps, needed for creating an ultra-high vacuum environment by conventional turbomolecular pump operation. This new pump is fully oil-free, compact and featuring exceptionally high compression performance. Development was centered on the minimization of vane clearance by introducing thin ceramic multi-stage centrifugal vanes, as well as optimal dynamic and sensor-less magnetic bearings.

**Keywords:** Atmospheric pressure type TMP, Ceramics centrifugal vane, Dynamic bearing, Backup pump, Sensor less magnetic bearing, Thrust force, Ultra high vacuum, Destructive torque



図1 従来の広域型TMP構造図  
Fig. 1 Structure of conventional wide range type TMP



図2 遠心翼の構造  
Fig. 2 Structure of centrifugal vane

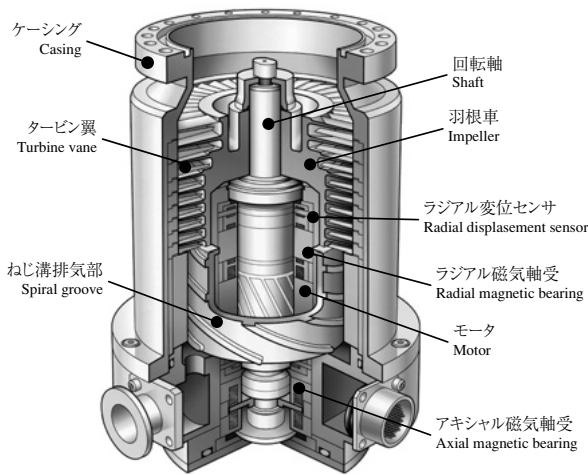

図3 大気圧ターボ分子ポンプ構造図  
Fig. 3 Structure of atmospheric pressure type TMP

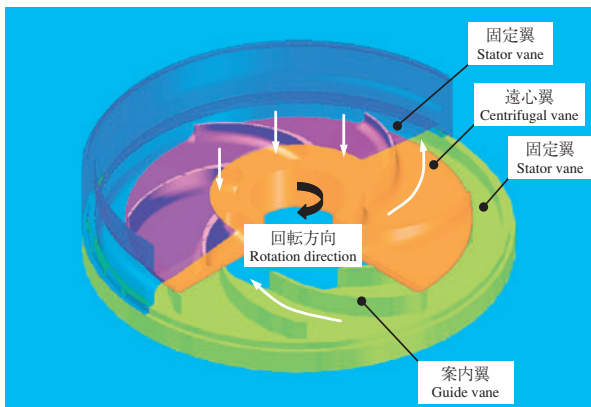

図4 セラミックス製遠心翼軸方向クリアランスと圧縮性能の関係  
Fig. 4 Effect of axial clearance on compression performance

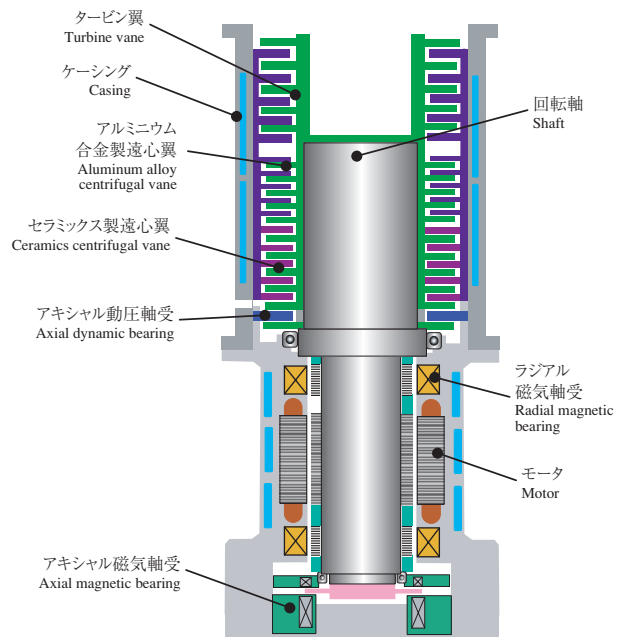

図5 動圧軸受部の構造  
Fig. 5 Structure of dynamic bearing section

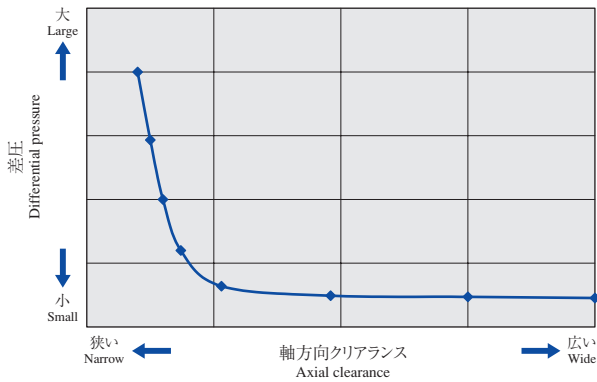

図6 クリアランスと反発力の関係  
Fig. 6 Relationship between clearance and repulsion force

表1 仕様  
Table 1 Specifications

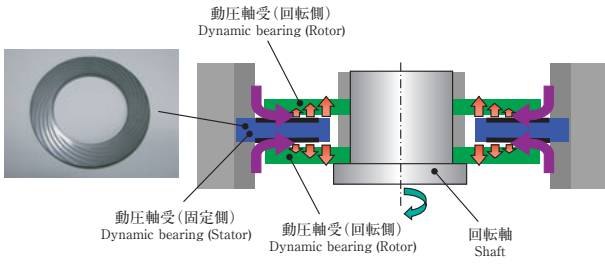
最大排気速度 N <sub>2</sub> Maximum pumping speed	60 L/s
到達圧力 Ultimated pressure	1 × 10 <sup>-5</sup> Pa
定格回転速度 Rated revolution	80000 min <sup>-1</sup>
軸受方式 Bearing system	ラジアル方向：磁気軸受 Radial : Magnetic bearing アキシャル方向：磁気軸受 + 動圧軸受 Axial : Magnetic bearing + dynamic bearing
冷却方式 Cooling system	水冷 Water cooling
ポンプ寸法 Pump size	φ 102 × 290 mm
ポンプ質量 Pump weight	11 kg

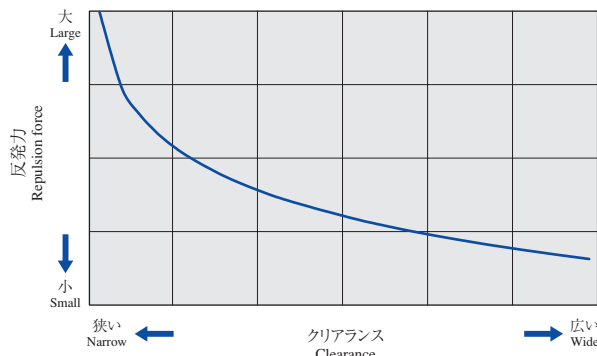
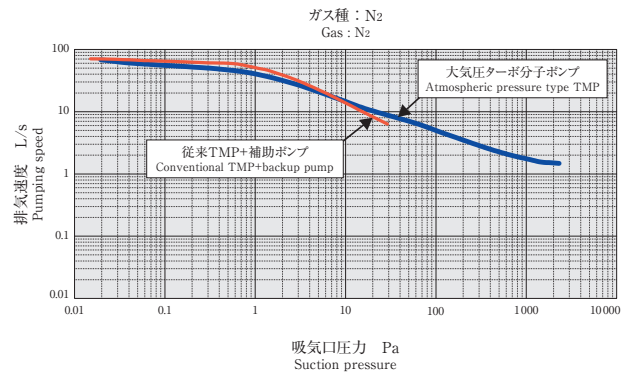

図7 排気速度カーブ  
Fig. 7 Pumping speed curve

表2 ロータ破壊時の発生トルクの比較  
Table 2 Comparison in generated torque at rotor destruction

	大気圧ターボ分子ポンプ Atmospheric pressure type turbomolecular pump	従来TMP Conventional TMP
回転速度 Revolution	80000 min <sup>-1</sup>	72000 min <sup>-1</sup>
発生トルク Generated torque	130 N·m	658 N·m